

Cvičenie 13.4.2022

Príklad 1

PROBLEM: A mathematical function has the integral representation

$$F_\nu(x) = \frac{1}{2} \left(\frac{x}{2}\right)^\nu \int_0^\infty \exp\left(-t - \frac{x^2}{4t}\right) t^{-\nu-1} dt,$$

where ν and x may be regarded as real, positive numbers.

With ν fixed, determine the *asymptotic* behavior of this function for $x \gg 1$.

Príklad 2

A hollow metal sphere of radius R and mass M floats on an insulating dielectric liquid of density ρ and relative dielectric constant ϵ_r . When the metal sphere has no charge on it, it floats on the dielectric liquid as shown in Figure 1(a); i.e., the bottom of the sphere is $R/2$ below the surface of the dielectric liquid.

- Determine the relationship between M and ρ when the sphere is *not* charged.
- The hollow metal sphere is now charged with a charge Q . Draw a diagram that shows all the charges and explain why the sphere sinks further into the dielectric liquid when it is charged.
- Find the magnitude of the charge Q to which the sphere must be charged in order for it to be half submerged as shown in Figure 1(b). Express your answer in terms of ρ , R , ϵ_r , the vacuum permittivity ϵ_0 , the acceleration due to gravity g , and other numerical factors.

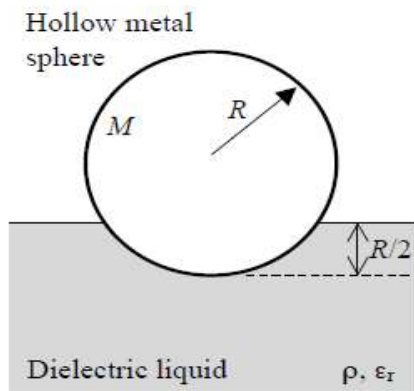

Figure 1(a)

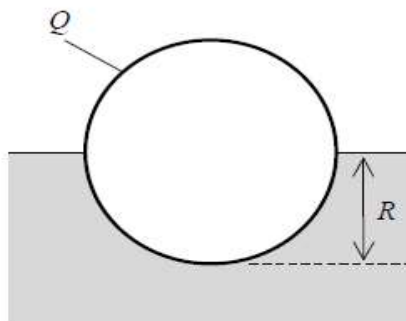

Figure 1(b)

Príklad 3

Consider an ideal gas of N_0 non-interacting spin-less particles each with kinetic energy

$$\varepsilon = \frac{m}{2} \vec{v}^2$$

that is contained in a box. The temperature of the gas is T_0 , and the particles are uniformly distributed throughout the box.

Compute the total energy $E_0 = \langle E \rangle$ of the N_0 particles in the box. Next, one instantaneously removes all particles from the gas that possess a kinetic energy larger than $nk_B T$ (n is an arbitrary real, positive number). How many particles remain in terms of N_0 ? What is the new total energy, E_{new} in terms of E_0 ? After the remaining particles have returned to equilibrium, what is the new temperature, T_{new} of the gas in terms of T_0 ?

Príklad 4

The following two problems are independent and should be solved using special theory of relativity.

- (a) A heavy nucleus of mass M staying at rest absorbs a relativistically fast neutron of mass m and velocity v , and then undergoes a fission process into two identical daughter nuclei of rest mass M' . The final velocities of the two daughter nuclei are collinear to the initial velocity of the neutron. Find the magnitude of the momenta of the two daughter nuclei in the center of mass frame of the pair.
- (b) A neutron at rest in the lab frame undergoes a β -decay

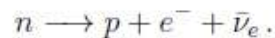

Let's assume that the electron e^- and neutrino $\bar{\nu}_e$ are massless, and their final momenta have the same magnitude, but make an angle 2θ , as in the figure. Express the angle θ in terms of neutron mass m_n , proton mass m_p , and the magnitude of the final proton momentum p_1 . From this, obtain the minimum and maximum values of p_1 , and the corresponding angles θ .

